

Languages of the World

The typology of color term

Based on teaching material by Reinhard Blutner

Basic questions

- Is our color perception influenced by our color terminology?



- Can any partition of the color space be used as basis for a system of color words?

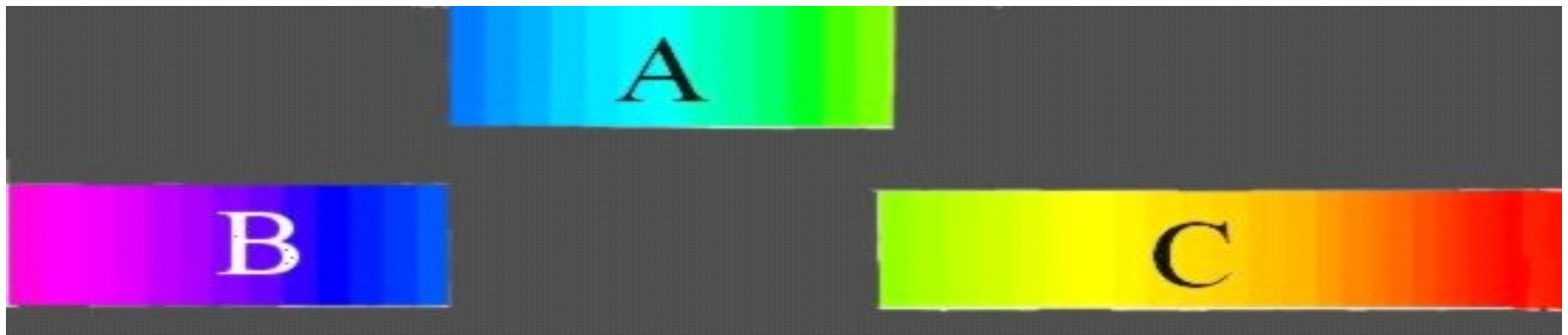

Color physics

Physically speaking, colors from a *spectrum*:
Identity of a color is determined by intensity
of radiation at every wave length



Sunlight

- Flat spectrum
- All wave lengths have roughly the same intensity
- Is perceived as *white*

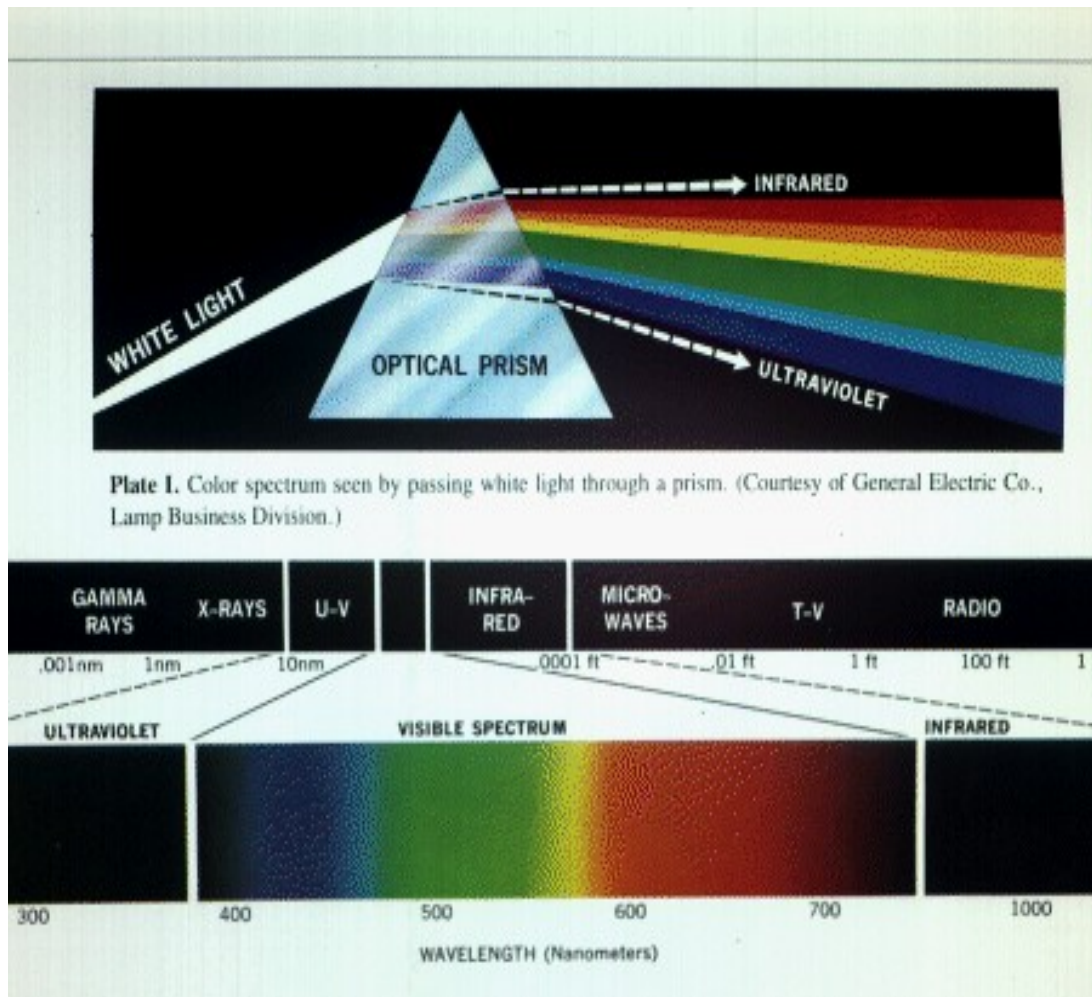

Can the human eye identify spectra?

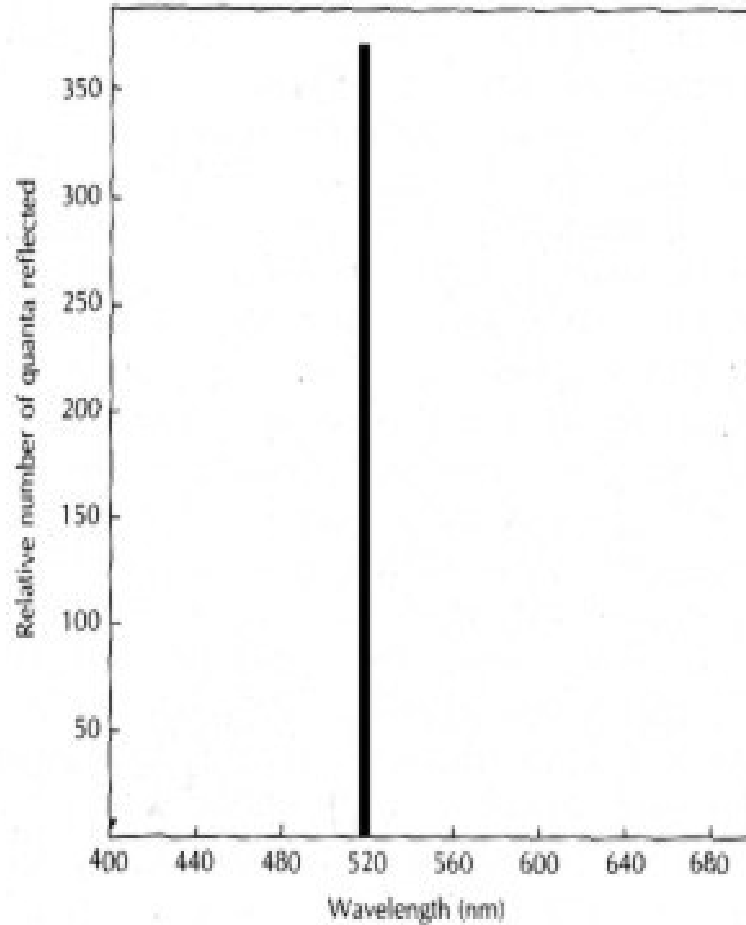
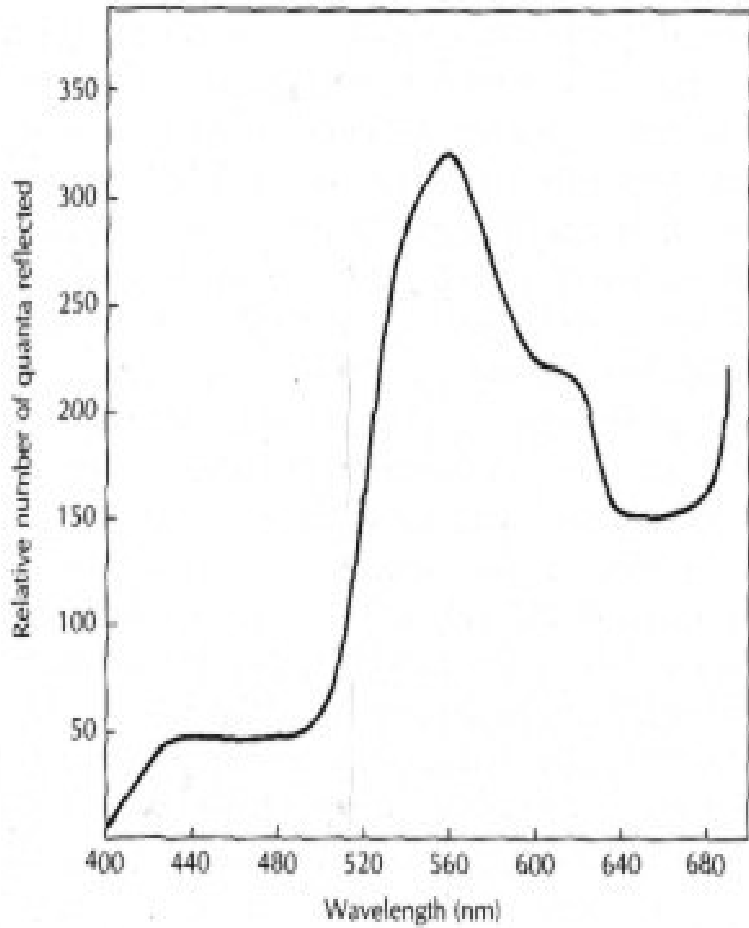

Spectra of grass and of monochromatic green

The color space

- Experiment show that humans identify every color with a combination of three basic colors
- Computer graphics: usually **red (645.16 nm)**, **green (526.32 nm)** and **blau (444.44 nm)**
- *Color space*: Set of all colors that a device (printer, screen, film, ...) can produce
- Depends on device
- Conversion between different color spaces is possible though

The RGB-model (additive color space)

- Defined 1931 by the Viennese Commission Internationale de l'Eclairage (CIE): **red** (645.16nm), **green** (526.32nm) and **blue** (444.44nm).
- Additive model:
white results from *adding* basic colors

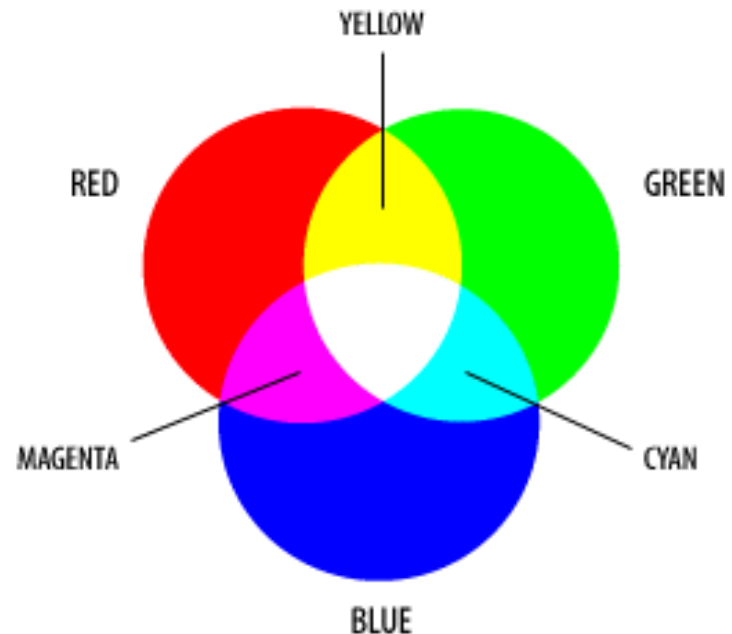

The CMY-model (subtractive color space)

- While screens and projectors emit light, printed paper absorbs or reflects light
- Cyan, magenta and yellow pigments *subtract* red, yellow and blue light from white

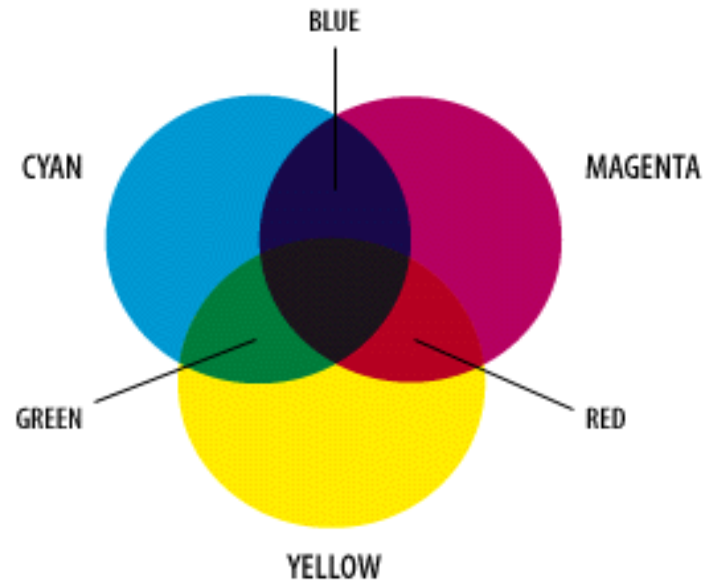

Conversions between **RGB** and **CMY**

RGB → CMY

$$C = 1 - R$$

$$M = 1 - G$$

$$Y = 1 - B$$

In general

$$\begin{pmatrix} c \\ m \\ y \end{pmatrix} = \begin{pmatrix} 1 \\ 1 \\ 1 \end{pmatrix} - \begin{pmatrix} 1 & 0 & 0 \\ 0 & 1 & 0 \\ 0 & 0 & 1 \end{pmatrix} \begin{pmatrix} r \\ g \\ b \end{pmatrix}$$











CMY → RGB

$$R = 1 - C$$

$$G = 1 - M$$

$$B = 1 - Y$$

$$\begin{pmatrix} r \\ g \\ b \end{pmatrix} = \begin{pmatrix} 1 \\ 1 \\ 1 \end{pmatrix} - \begin{pmatrix} 1 & 0 & 0 \\ 0 & 1 & 0 \\ 0 & 0 & 1 \end{pmatrix} \begin{pmatrix} c \\ m \\ y \end{pmatrix}$$

RGB				CMY		
0	0	0		255	255	255
255	0	0		0	255	255
0	255	0		255	0	255
0	0	255		255	255	0
255	255	0		0	0	255
0	255	255		255	0	0
255	0	255		0	255	0
255	255	255		0	0	0
153	102	51		102	153	204
204	153	51		51	102	204

Problems with RGB and CMY

- Not accessible for introspection
- Perceptually non-linear; the same distance in RGB space is sometimes perceivable and sometimes not

Various color spaces

- Computer monitor, color TV: RGB
- Color printer: CMY
- Psychological color perception
 - lightness
 - hue
 - saturation

The HSL color space

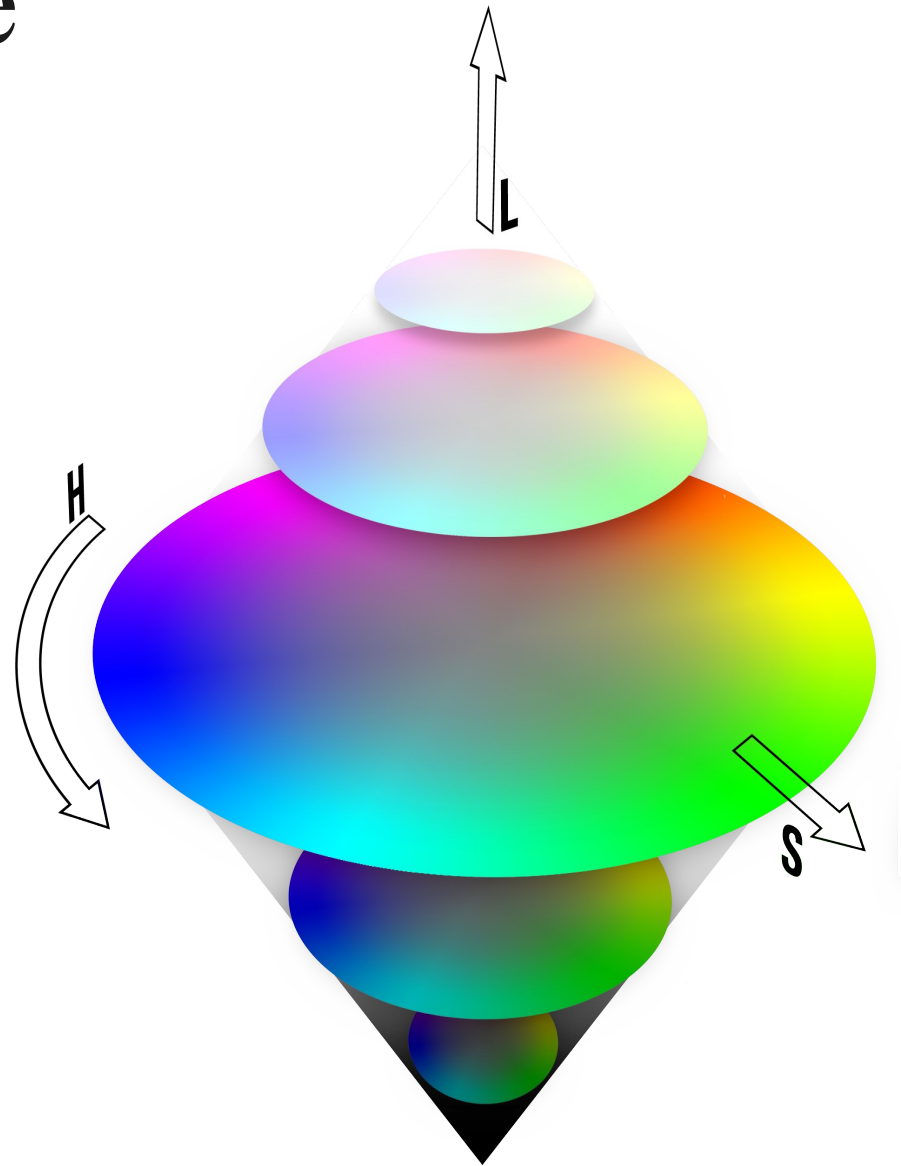

H = Farbton (Hue)

S = Sättigung (Saturation)

L = Helligkeit (Luminance)

Hue

The hue determines which basic color it is: red, green, blue, yellow, orange, etc. A hue is referenced by an angle on a color wheel. For a certain hue, the ratio of each primary (RGB) color to the other is fixed.

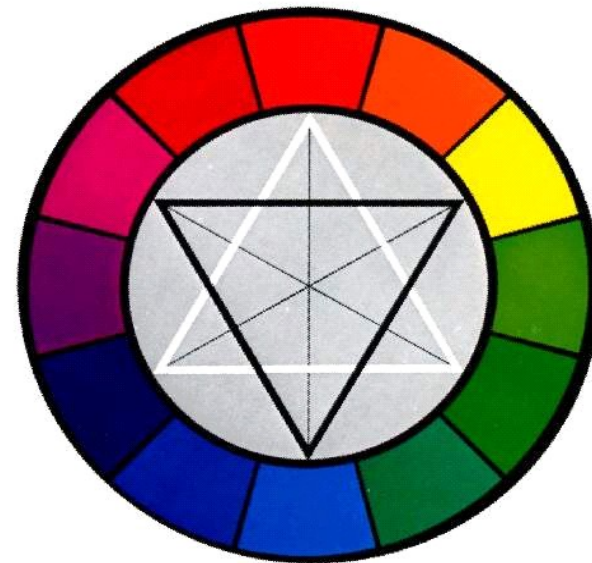
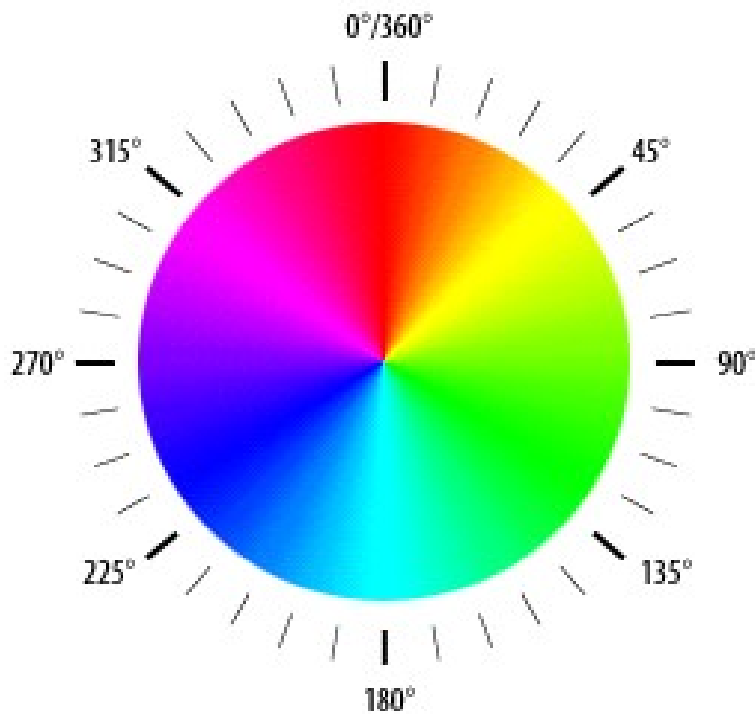

Saturation

This parameter controls how intense or gray the colour becomes. Lowering saturation equalizes the ratio between each of the primary (RGB) colours resulting in lower contrast and at its extreme a grey screen. Increasing saturation increases the ratio between the predominant primary colour and the subordinate primary colour resulting in increased contrast.



Lightness

It increases the “brightness” of the particular hue. Lowering Luminance has the characteristic of reducing the numerical value of the primary colors while keeping the ratios the same.

Increasing the luminance in turn increases the numerical value of the primary colors while keeping the ratio the same until one primary color reaches its maximum, then the hue becomes pastel as the other two primary color values continue to increase until the image finally becomes pure white at maximum luminance. This mimics the eye response in nature since as things become brighter they look more pastel until they become washed out.

100% ←—————→ 0%



Munsell color space

Discrete color space where distance in space roughly corresponds to perceptual distance

Attributes (as in HSL):

Munsell Hue (H) – hue

Munsell Chroma (C) – saturation

Munsell Value (V) – lightness

Because of its perceptually uniform property, it is recognized as a standard system of color specification and has been widely used in many fields of color science.

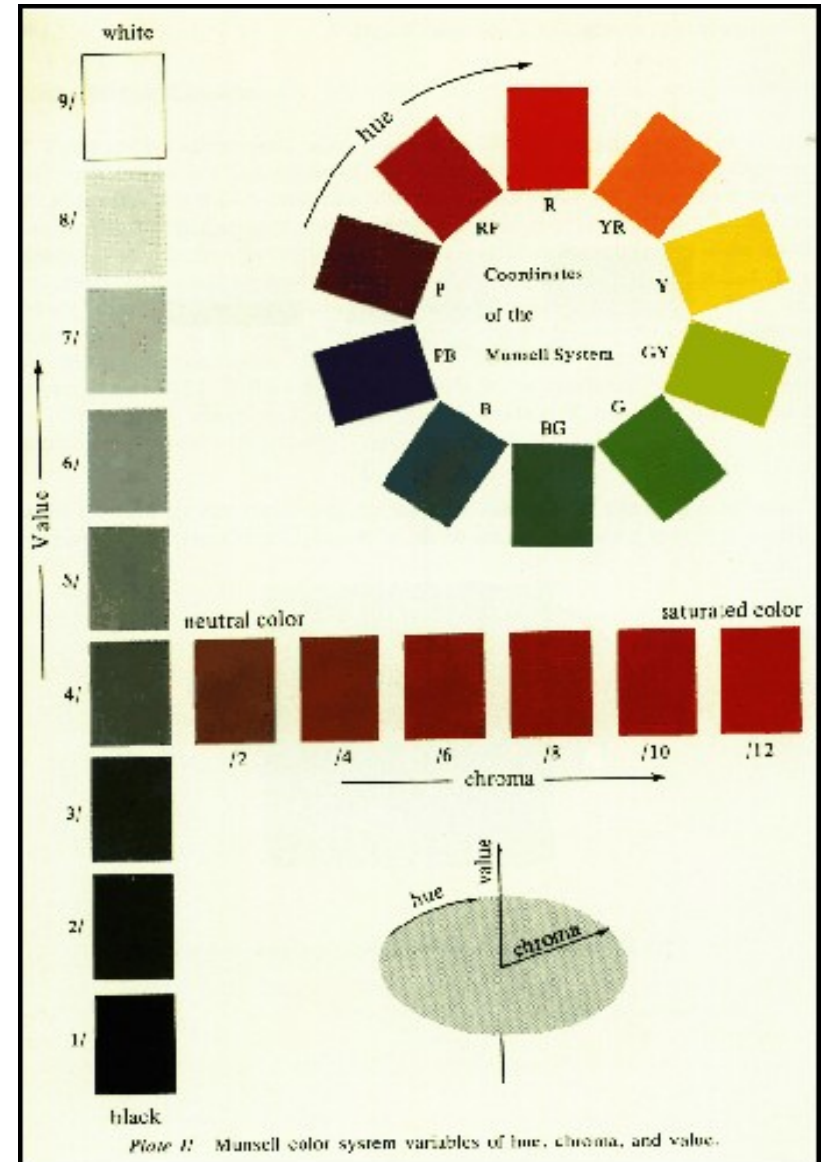

Munsell color tree

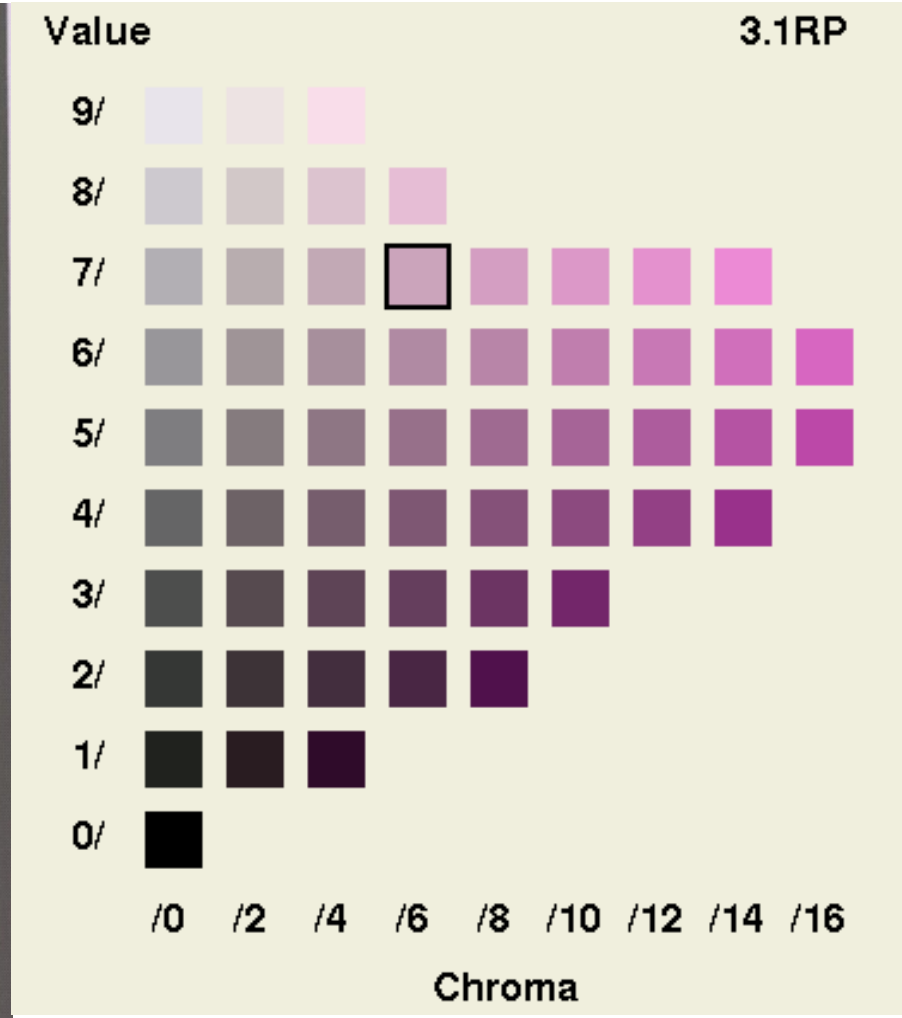
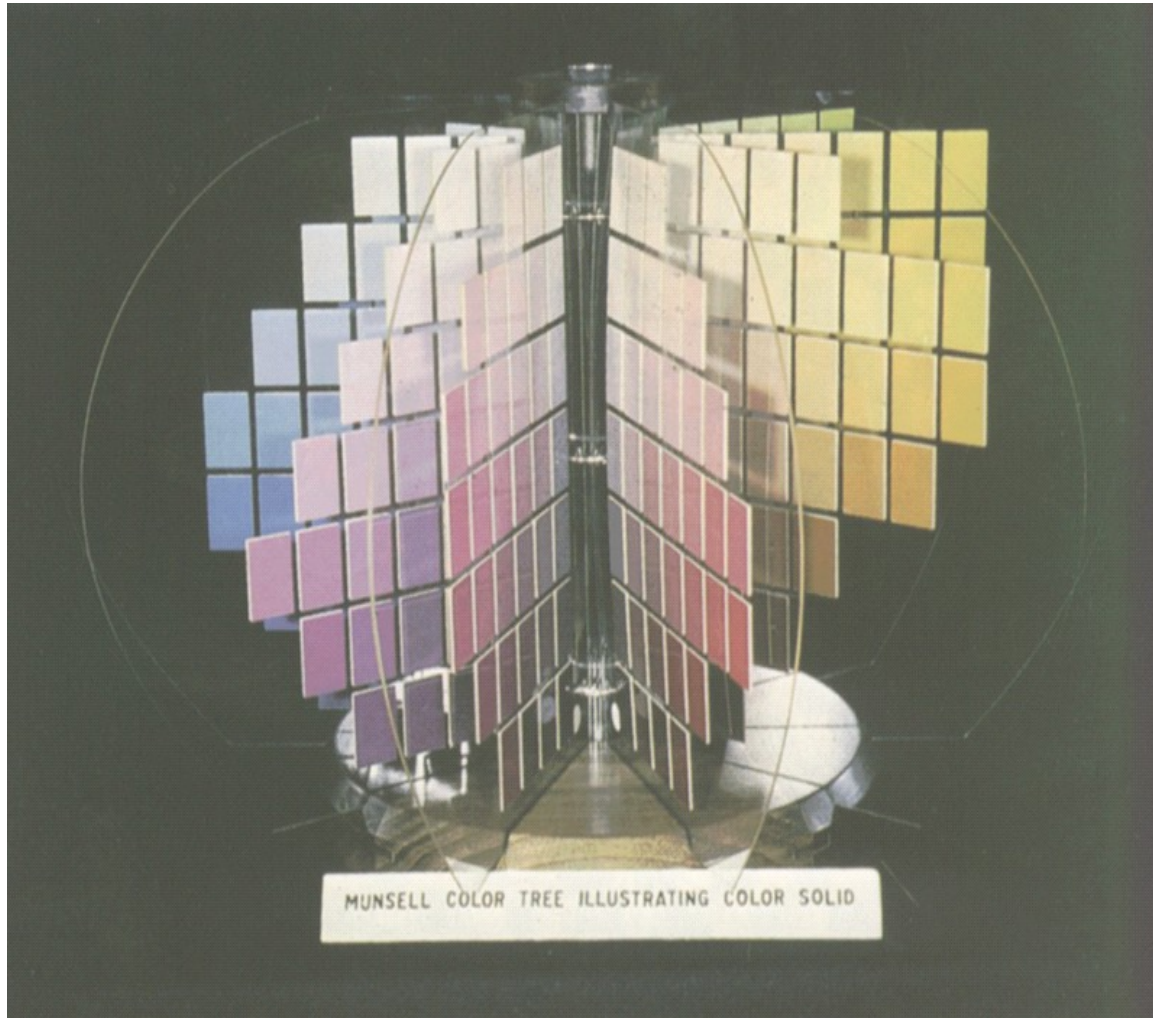

Trichromacy

- Color perception (a.o.) via *cones* (light sensitive nerve cells at the retina)
- Three kinds of cones – sensitive to different bands of wave lengths

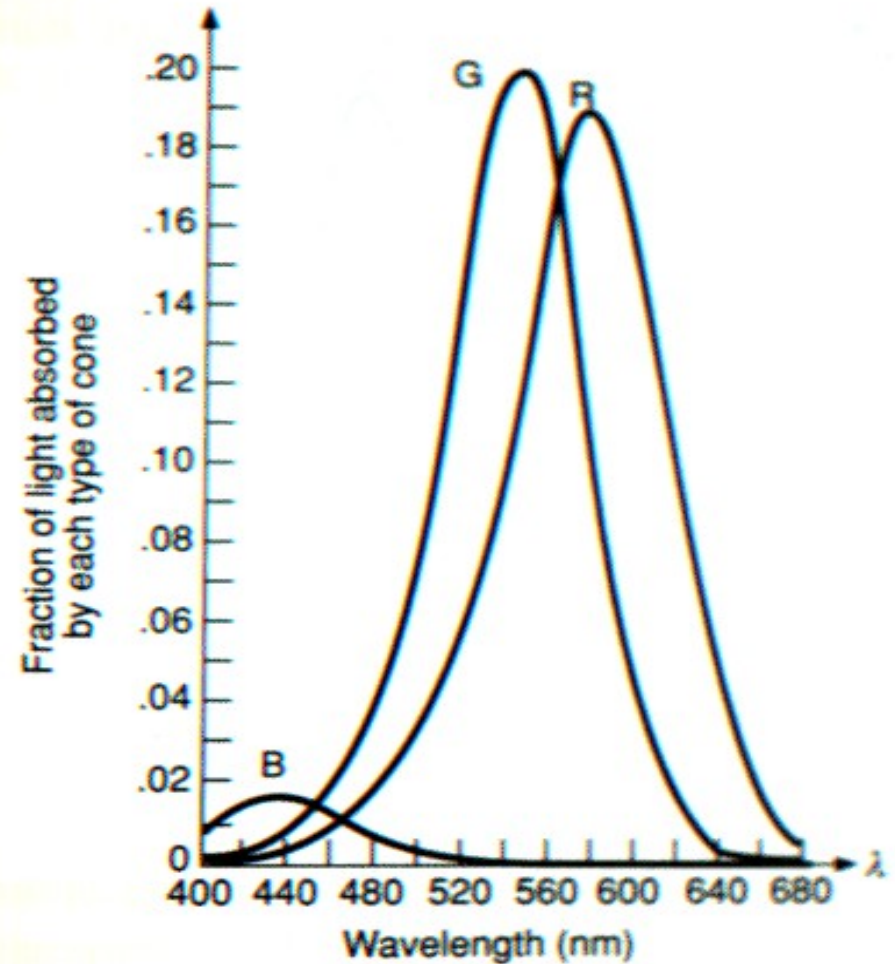

Pros and cons of the trichromacy hypothesis

- Advantages:
 - Physiological correlat (cones in retina)
 - Explains why all colors can be represented in RGB model
- Disadvantages
 - Cannot explain phenomenon of complementary colors

Complementary colors



Fixate the star at the center of the image!

Complementary colors

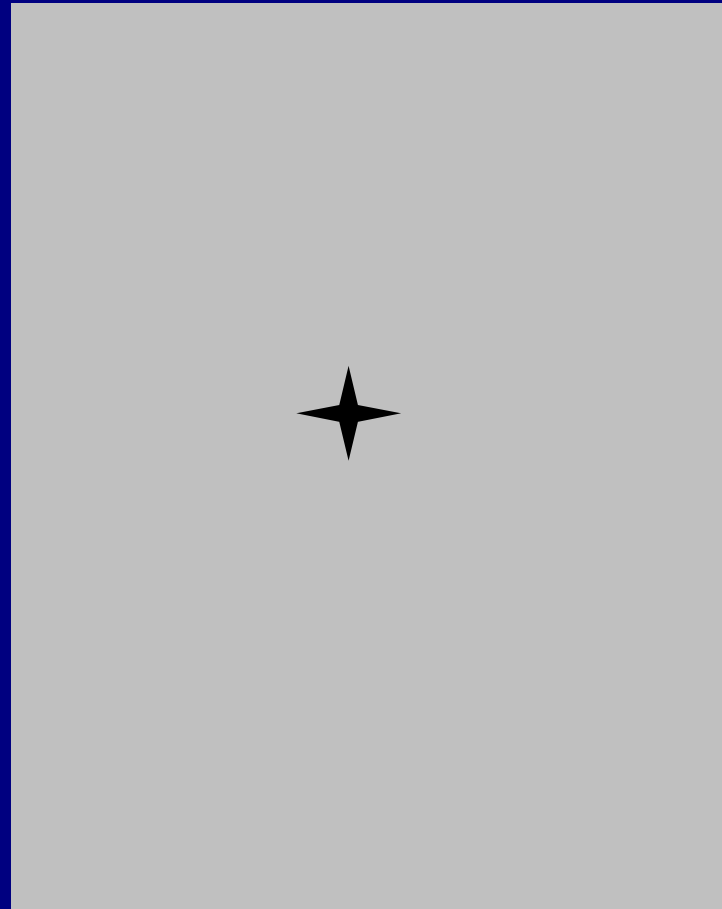

Fixate the star at the center of the image!

Tetrachromacy

- Hering (1875): Color perception is based on three oppositions:
 - red – green
 - yellow – blue
 - light – dark
- Three-dimensional space as well!

Physiology of color perception

(A) Retina
Trichromacy

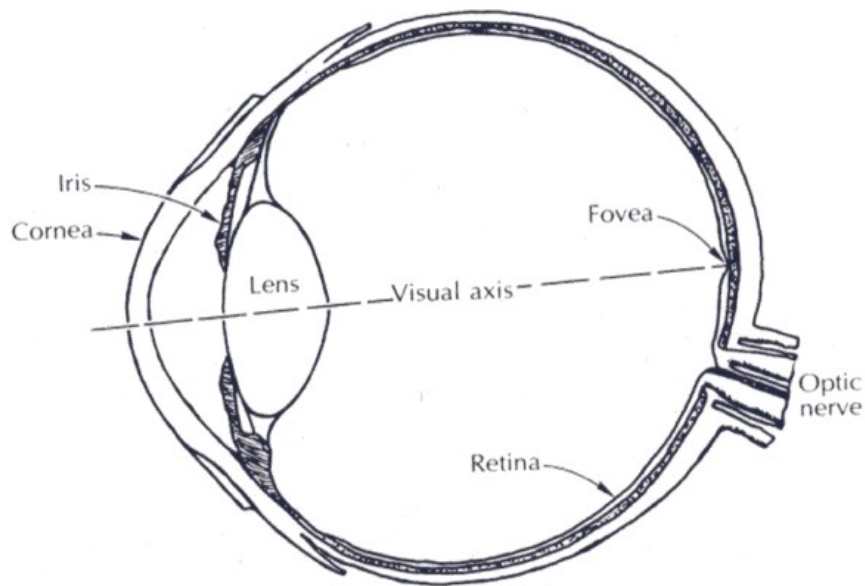

(B) visual cortex
Tetrachromacy

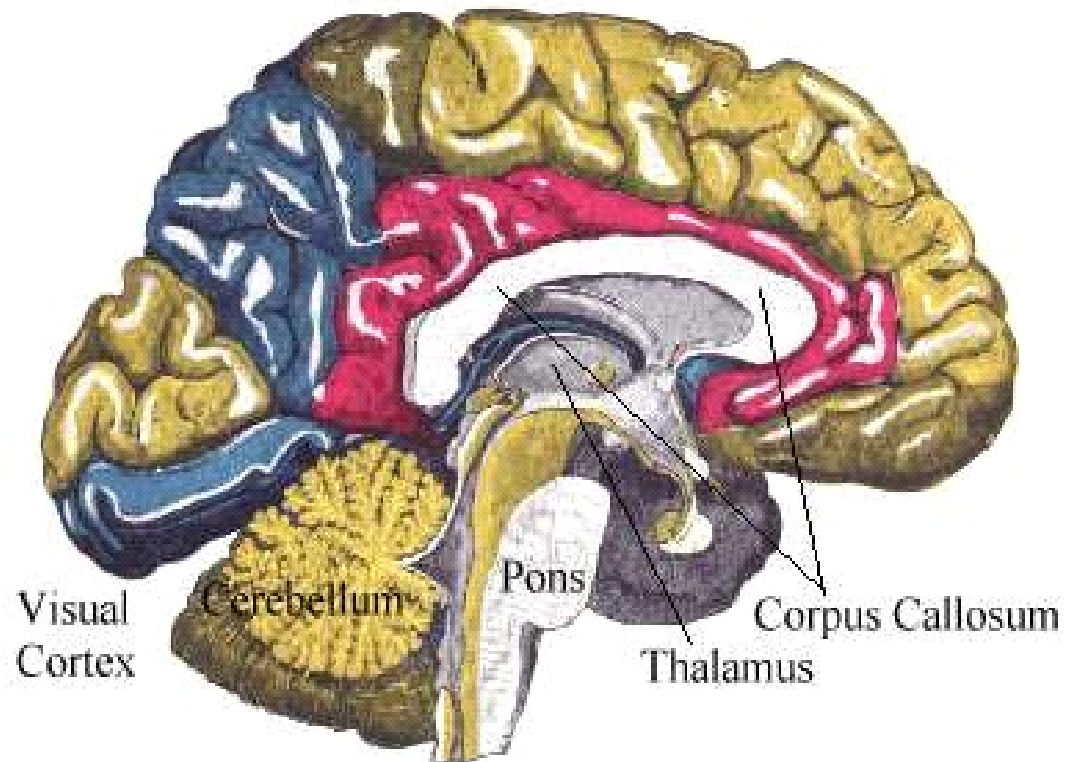

Four type of opponent cells in the macaque's LGN

LGN = lateral geniculate nucleus

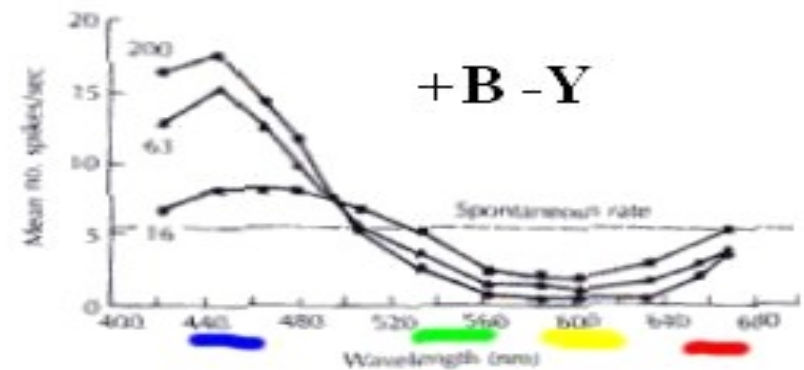
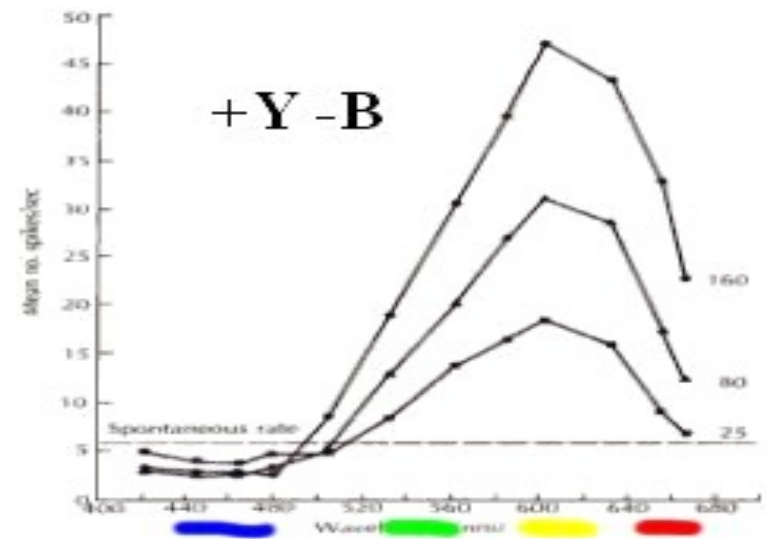
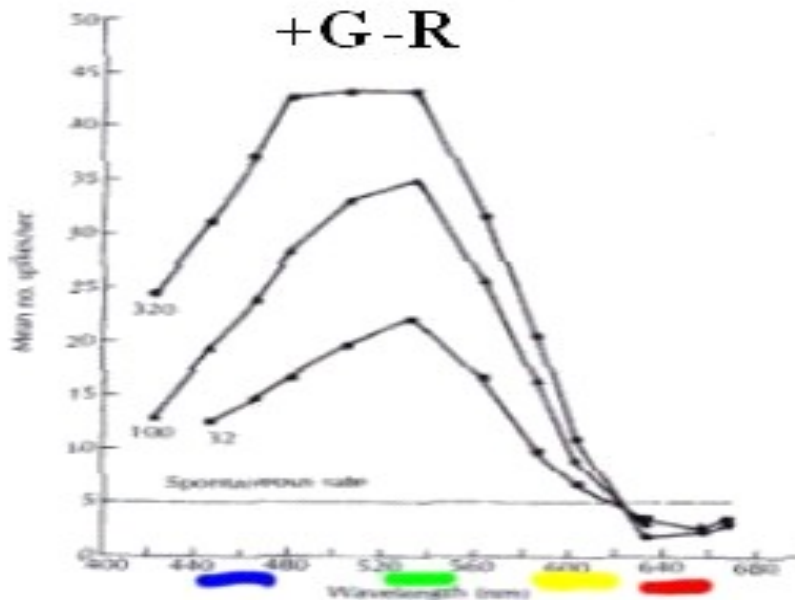
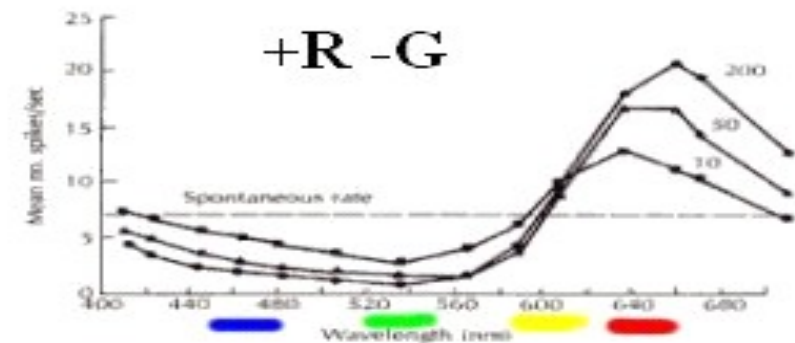

Summary color spaces

- RGB model has correlate in retina cells
- Hering's model has correlate in visual cortex
- Hering's model and HSL color space are isomorphic
- HSL is best representation of psychological reality

Summary color spaces

- Most important aspects of Hering's tetrachromacy thesis:
 - Red, green, yellow and blue are primary colors with a special status
 - Psychological evidence: primary colors are easier to remember than other colors

Color terms

- Color categories carve up the color space in partially overlapping subsets
- Color categories are prototype categories

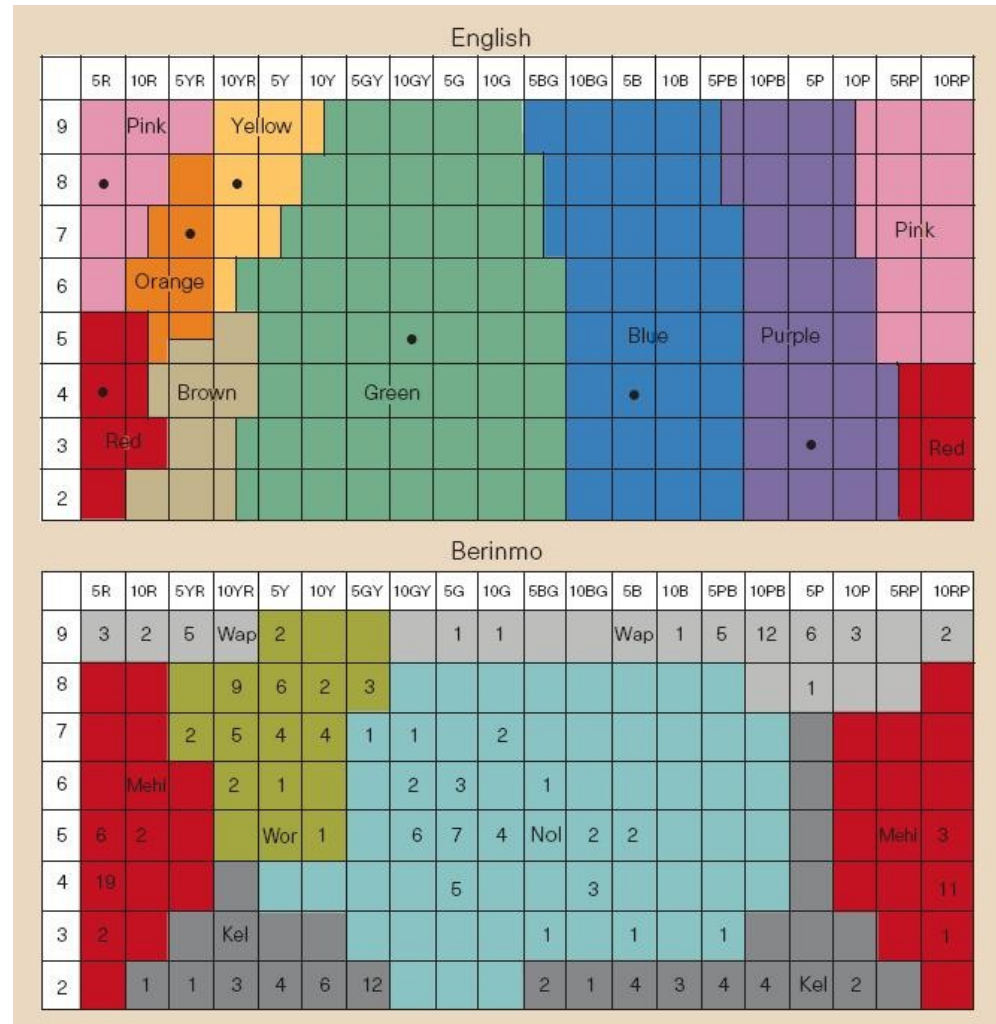

Prototypes

- Some colors are better examples for a category than others
- Usually there is one optimal example for a color category (a “prototype”)
- Colors that are far away from the prototype in color space are poor examples for the category in question
- Boundaries of color categories are blurred

Berlin and Kay (1969)

- Comparison of color term vocabulary in different languages
 - Focus on **basic** color terms (one morpheme, no recent borrowing, general vocabulary, ...)
 - Focus on typical elements of a category (not just on category boundaries)
 - Usage of Munsell chips

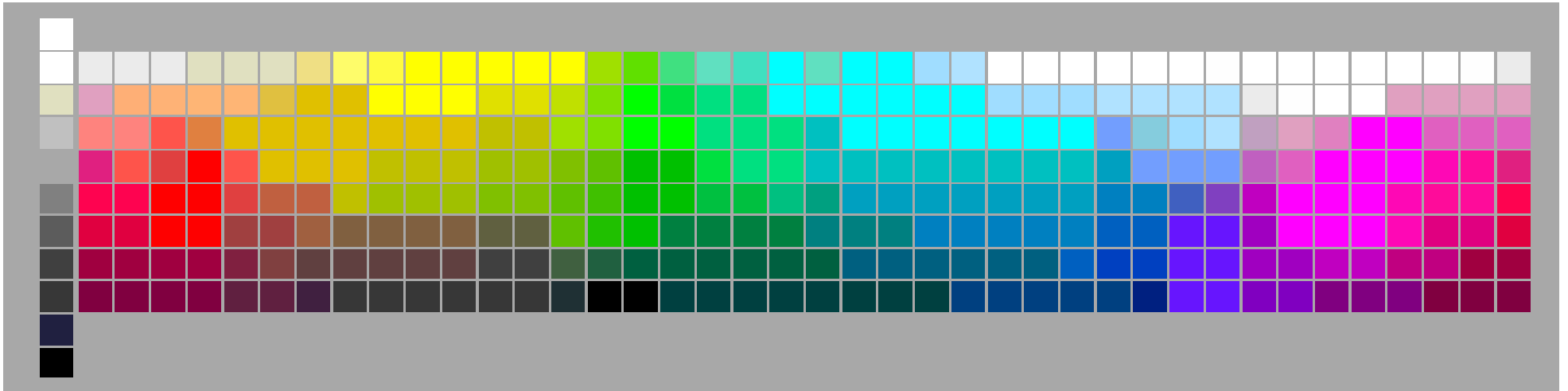

Basic color vocabulary

Crimson, red, orange, scarlet, yellow, lemon-coloured, blond, green, blue-green, blue, bluish, purple, pink, brown, grey, black, white,

- Monolexemic (*lemon-colored, *blue-green)
- Their extensions aren't included within those of any other colour terms (*crimson: red, *scarlet: red)
- Applications must not be restricted to a narrow class of objects (*blond: humans)
- psychologically salient for informants (*crimson, *scarlet, *bluish, ...)

Basic color vocabulary

Crimson, red, orange, scarlet, yellow, lemon-coloured, blond, green, blue-green, blue, bluish, purple, pink, brown, grey, black, white,

- Monolexemic (*lemon-colored, *blue-green)
- Their extensions aren't included within those of any other colour terms (*crimson: red, *scarlet: red)
- Applications must not be restricted to a narrow class of objects (*blond: humans)
- psychologically salient for informants (*crimson, *scarlet, *bluish, ...)



Hence, we have 11 basic colour terms in English: red, orange, yellow, green, blue, purple, pink, brown, grey, black and white.

Method

- 98 languages were investigated
- Informants were asked
 - to name the basic color terms of their native language, and
 - to identify both the focal points and the extension of each of these words on a Munsell chart

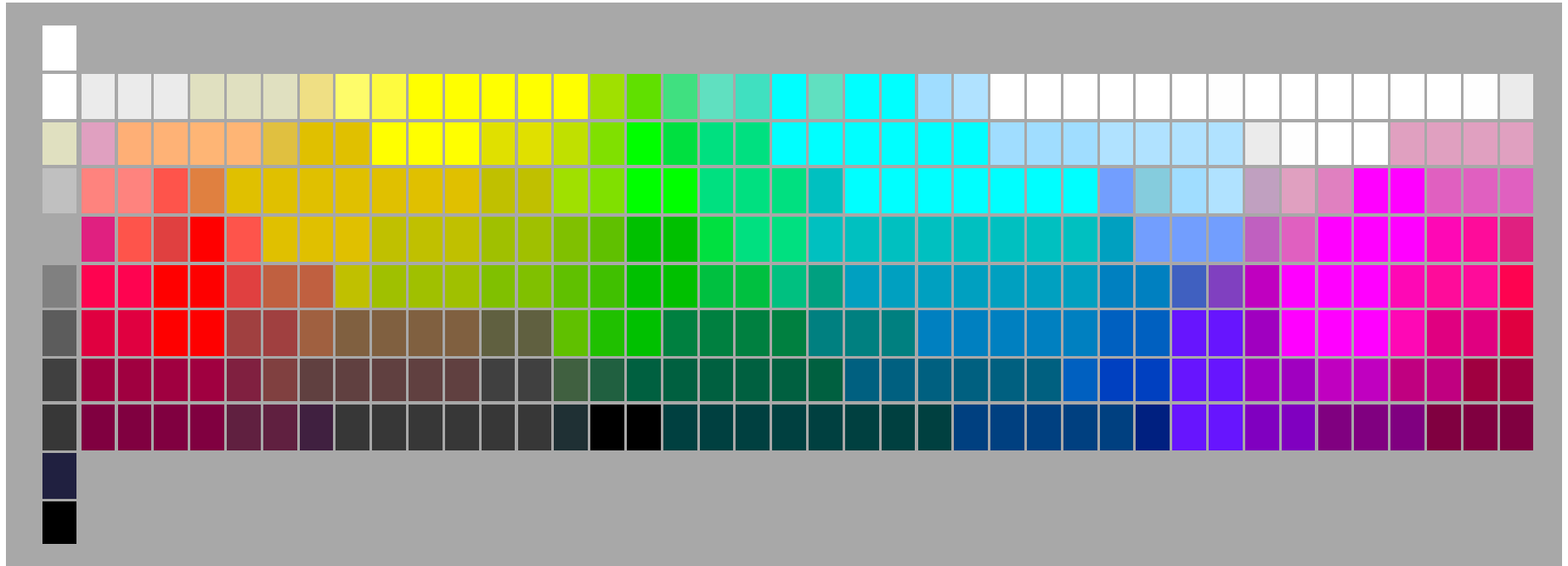

40 “equally spaced” steps in color space

8 degrees of lightness

All 320 colors have maximal saturation

Additionally 9 chips of neutral hue

Results (1969)

- The number of basic colour terms is between 2 and 11(12).
- If a language has 11 basic colour terms, then the encoded categories are WHITE, BLACK, RED, GREEN, YELLOW, BLUE, BROWN, ORANGE, PINK, PURPLE, and GREY



- Languages with 11 (12) basic colour terms: Arabic (Lebanese), Bulgarian, English, German, Hebrew, Hungarian (12!), Japanese, Korean, Russian (12!), Spanish, Zuni, ...
- If a language has fewer than 11 basic colour terms, then there are strict limitations on which categories it may encode.











Results (1969)

- If a language has less than 11 color terms, then there are clear restrictions:
 - Only 22 different color vocabularies
 - Can be described by 7 *implicative universals*

Results (1969)

- (I) All languages have words for *white* and *black*
 - (II) If a language has three color terms, then it has a word for *red*
 - (III) If a language has four color terms, then it either has a word for *green* or for *blue*
- ...

Results (1969)

WHITE BLACK		< RED <	GREEN YELLOW	< BLUE <	BROUWN	PURPLE PINK ORANGE GREY
I	II	III/IV	V	VI	VII	
 		 			   	

Results (1969)

- Prototypes of all basic color terms from all languages form discrete clusters
- Test persons are very consistent in identification of prototypes, but not so much in identification of category boundaries
- Total of 11 (!) prototype clusters

Evolution of color vocabulary

- speculation
 - Languages all start/started with two color terms
 - New color terms are added later
 - Basic color terms are not lost in language change
 - 11 color terms is maximum

Evolution of color vocabulary

- Speculation (Cont.)
 - The 7 language types mentioned above correspond to stages in this sequence

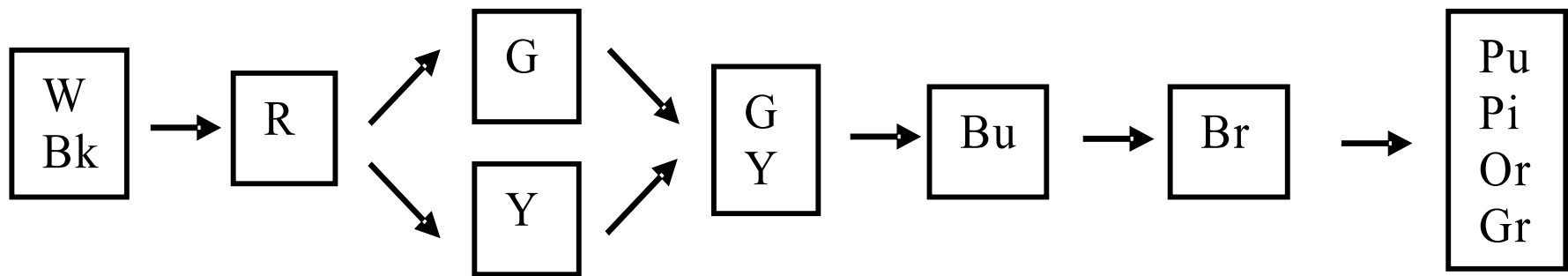

I

II

III

IV

V

VI

VII

Conclusions (1969)

- Color perception is independent from color vocabulary
- Color perception restricts possible categorizations
- Strong evidence against linguistic relativism

Later revisions

Kay & McDaniel (1978); Kay, Berlin, Maffi & Merrifield (1997);
Kay & Maffi (1999)

- *Grey* emerges earlier than at stage VII, sometimes already at state III (Mandarin, Hopi, Tsonga)
- Some languages do not distinguish *green* and *blue*, but have words for “later” colors like *brown* (Bantu languages)
- Only 6 salient perceptual landmarks (rather than 11):
 - *Black, white, red, green, blue, yellow*

Later revisions

- Correspond to the poles in Hering's tetrachromatic model
- Vast majority of basic color terms in all languages denote one or several of these six primary colors
- The terms in the two-color systems do not simply denote *black* and *white*, but they partition the entire color space

B&K
1969

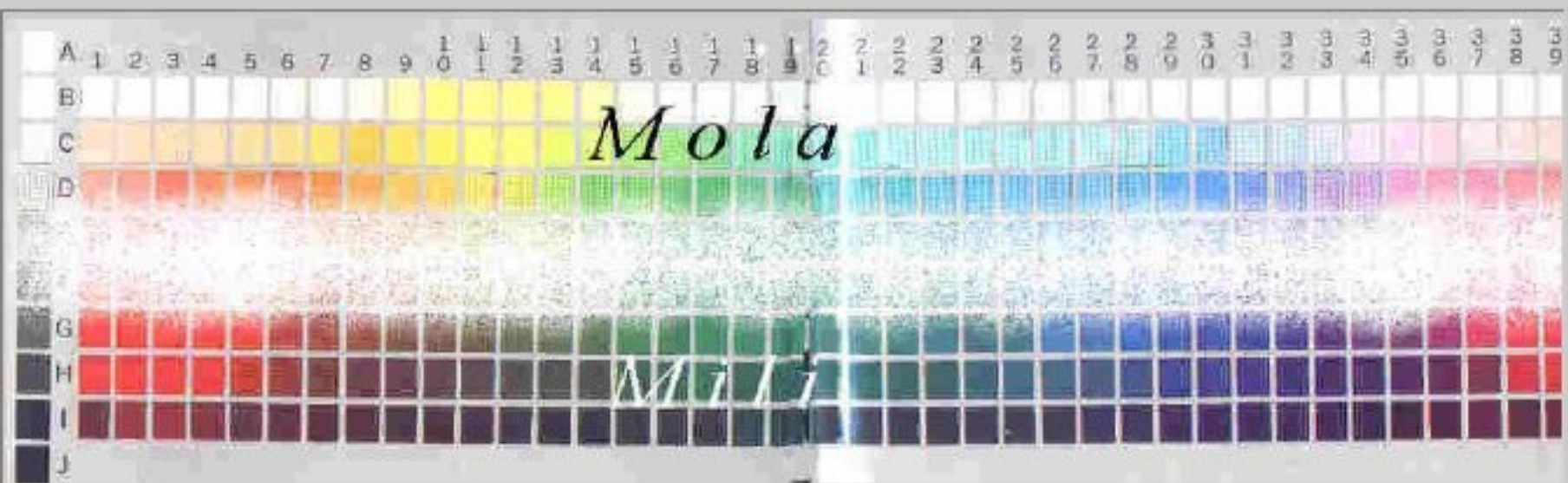

Revision
1978

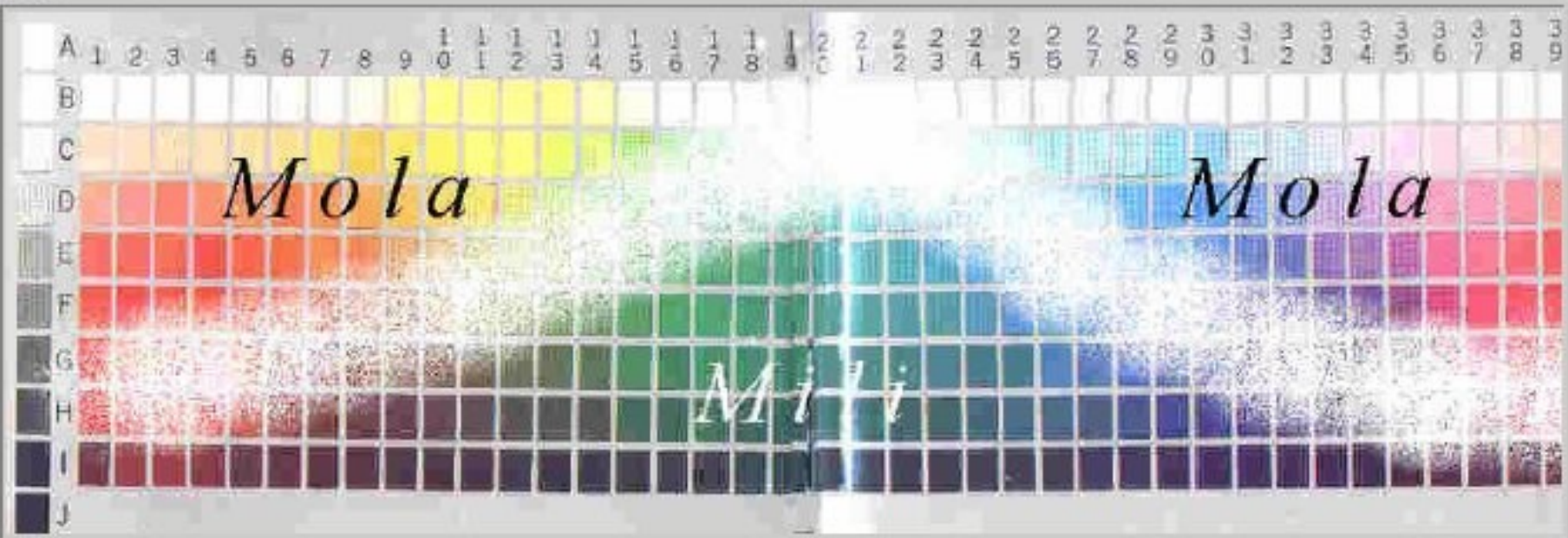

Dani (language from Papua/New Guinea): Partition of the color space into "warm" and "cool" colors

Later revisions

- Next to the six primary colors there are derived color categories (so-called *fuzzy intersection*) and composite basic categories (like “warm colors”)

orange = red \cap yellow

warm = red \cup yellow

Later revisions

- Every color category system partitions the color space. Evolutionary sequences move from coarser to finer partitions

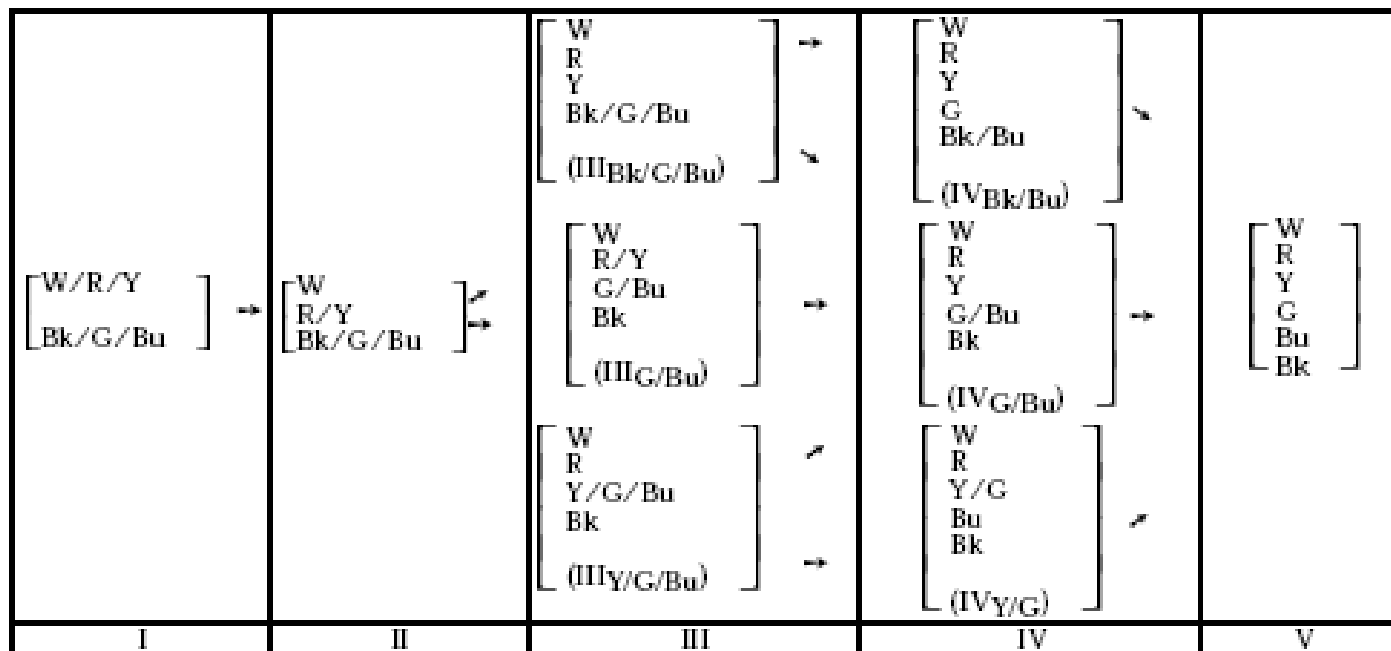

from Kay & McDaniel (1978)